

Smart Drain

电子零气耗排水器

Electronic Zero Loss Drain

说明:以 SD-800E 为范本,介绍 Smart Drain 系列电子零气耗排水器的安装使用。

安全提示: 在安装和维护排水器之前, 排水器必须处于断电、无气压状态!

Safety Warning: The drain valve must be in a state of power off and no pressure before cleaning and maintaining it!

结构 Structure

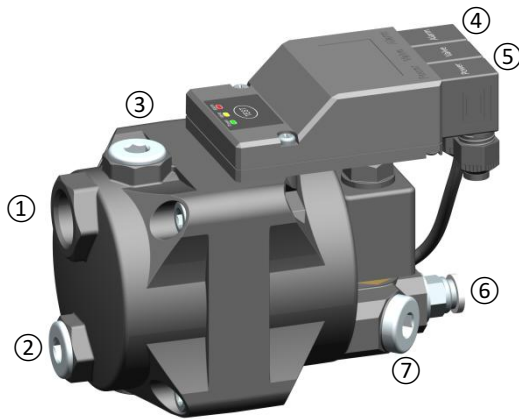

- ① 入水口
Inlet
- ② 备用接口
Spare port
- ③ 平衡管接口 (必要时使用)
Port of air balance pipe
(To be used if necessary)
- ④ 报警接线盒
Alarm connector
- ⑤ 电源接线盒
Power connector
- ⑥ 出水口
Outlet
- ⑦ 外置滤网堵头
Plug of external mesh

安装 Installation

排水器安装 Installation of drain

排水器入水口 G3/4" (通常不需要设置平衡管)
G3/4" inlet thread of drain (Usually need not balance pipe)

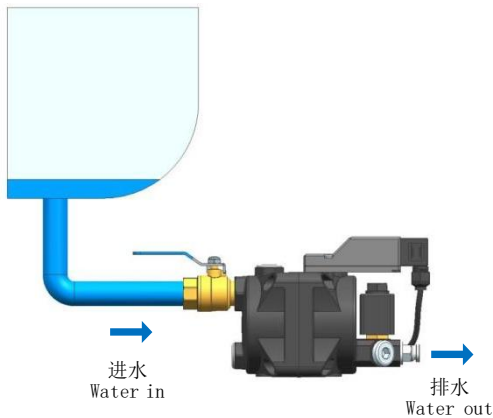

排水器入水口 G1/2" (需要设置平衡管)
G1/2" inlet thread of drain (Balance pipe is needed)

